



MINIATURE PRESSURE REGULATORS

Miniature Pressure Regulators

Regulators are offered in either relieving or non-relieving versions. The relieving design maintains a constant pressure output even when downstream conditions change. As downstream pressure increases due to reduced flow, this increased pressure overcomes the regulator piston and the pressure is relieved to atmosphere to maintain a constant output pressure.

The non-relieving regulator does not automatically compensate for changes in downstream flow or pressure. There is no vent to atmosphere, as in a relieving type regulator, and the output pressure can increase due to a downstream flow.

- Panel mounting permits unit to be located with other controls on a control console or panel board for pilot operation of larger regulators or for remote control; mounting nuts and lockwashers furnished
- Small, compact - ideal for mounting on individual jigs and fixtures as well as in control circuits

Medium: Air

Materials: Brass body, Buna-N seals, stainless steel stem and spring

Air Flow: 3 SCFM @ 50 psig; 5 SCFM @ 100 psig; 120 l/min. @ 6 bar

Input Pressure: 300 psig/21 bar max.

Mounting: 15/32-32 thread. Nuts and lockwashers furnished

Adjustment: By means of a knob with micro-adjustment (40 pitch thd.)

Adjustable Pressure Regulators

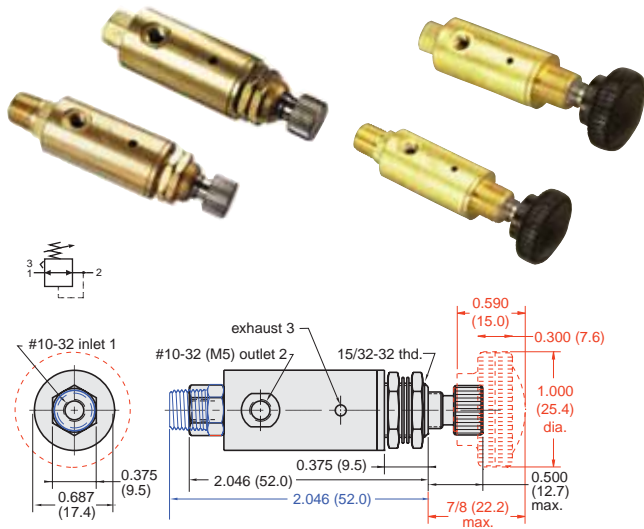

Plunger-Type Pressure Regulators

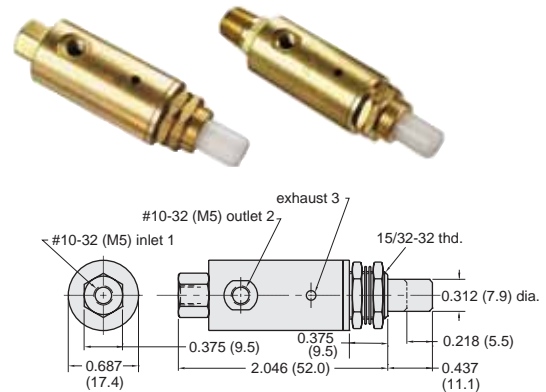

Plunger Travel: 7/32"

Force For Full Stem Travel: 25 lb nominal

Operation: As plunger is depressed pressure increases proportionally to the travel; when plunger is released the input is closed and the output pressure is exhausted to atmosphere

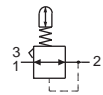

Range (psig/bar)	#10-32	Knob	1/8" NPT	Non-Relieving	M5
0-20/1.4	MAR-1-2	MAR-1K-2	MAR-1P-2	MAR-1NR-2	MAR-1-2-M5
0-30/2.1	MAR-1-3	MAR-1K-3	MAR-1P-3	MAR-1NR-3	MAR-1-3-M5
0-40/2.8	MAR-1-4	MAR-1K-4	MAR-1P-4	MAR-1NR-4	MAR-1-4-M5
0-50/3.4	MAR-1-5	MAR-1K-5	MAR-1P-5	MAR-1NR-5	MAR-1-5-M5
0-60/4.1	MAR-1-6	MAR-1K-6	MAR-1P-6	MAR-1NR-6	MAR-1-6-M5
0-70/4.8	MAR-1-7	MAR-1K-7	MAR-1P-7	MAR-1NR-7	MAR-1-7-M5
0-100/6.9	MAR-1	MAR-1K	MAR-1P	MAR-1NR	MAR-1-M5

Range (psig/bar)*	#10-32	1/8" NPT	M5
0-20/1.4	MAR-1C-2	MAR-1CP-2	MAR-1C-2-M5
0-30/2.1	MAR-1C-3	MAR-1CP-3	MAR-1C-3-M5
0-40/2.8	MAR-1C-4	MAR-1CP-4	MAR-1C-4-M5
0-50/3.4	MAR-1C-5	MAR-1CP-5	MAR-1C-5-M5
0-60/4.1	MAR-1C-6	MAR-1CP-6	MAR-1C-6-M5
0-70/4.8	MAR-1C-7	MAR-1CP-7	MAR-1C-7-M5
0-100/6.9	MAR-1C	MAR-1CP	MAR-1C-M5

* Outlet pressure is based on 7/32" stem travel. If stem is depressed further, the outlet pressure will increase.